



**INSTASTART™ Electronic Ignition  
Standard Ignition**

## Propane Stoves

**Camp Stove**

## Instructions for use

© 2014 The Coleman Company, Inc.  
www.coleman.com

### 9966 Series

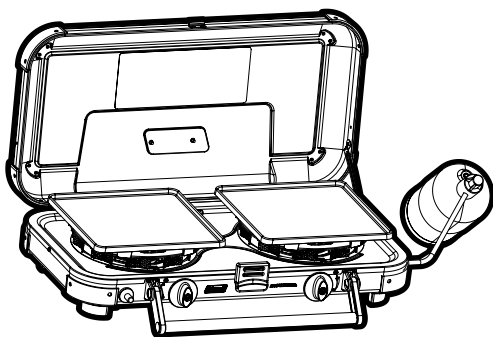

\* The griddles are only included for certain models.

#### IMPORTANT

Read these instructions for use carefully. Familiarise yourself with the appliance before connecting it to its gas container. Keep these instructions for future reference.

This instruction manual contains important information necessary for the proper assembly and safe use of the appliance. Follow all warnings and instructions when using the appliance. If you have questions about assembly, operation, servicing or repair of this product, please call Coleman on 1800 224 350 or + 61 2 8762 5000. Coleman Brands Pty Ltd. ABN 74 091 681 195, Suite W2C1, 75-85 O'Riordan Street, Sydney Corporate Park, Alexandria, NSW 2015, Australia.

Gas cylinders shall be changed in a well-ventilated location, preferably outside away from people and any sources of ignition, such as naked flames, pilot flames, electric heaters / equipment. If there is a leak on your appliance (smell of gas) and you cannot stop the gas flow, remove the appliance to a well-ventilated location away from any ignition source. Check for leaks using soapy water. Do not try to detect leaks using a flame. This appliance must only be serviced by an authorised person. Gas cylinders must be stored outdoors in a well ventilated area out of the reach of children, any indoor storage shall comply with AS/NZS 1596.

This appliance shall only be used with Propane LPG Coleman disposable gas cylinders certified to DOT-39 NRC 232/290 M1110. OR refillable Propane LPG cylinder certified to AS2030 & Coleman hose assembly. IT MAY BE HAZARDOUS TO ATTEMPT TO FIT OTHER TYPES OF GAS CONTAINERS. DO NOT USE ADAPTORS.

**CAUTION:** Accessible parts may be very hot. Keep young children away, USE OUTDOORS ONLY. Must only be operated on a horizontal surface. Not suitable for marine environments. Do not modify this appliance.

## FOR YOUR SAFETY

**If you smell gas:**

- 1. Do not attempt to light appliance.**
- 2. Extinguish any open flame.**
- 3. Disconnect from fuel supply.**

## DANGER



- Only use in well-ventilated areas.**
- Carbon monoxide hazard - using this appliance in an enclosed space may cause death.**
- Do not use in caravans, tents, marine craft, cars, mobile homes or similar locations.**

## FOR YOUR SAFETY

**Do not store or use gasoline or other liquids with flammable vapors in the vicinity of this or any other appliance.**

This manual contains important information about the assembly, operation and maintenance of this outdoor propane appliance. General safety information is presented on this page and is also located throughout these instructions. Particular attention should be paid to information accompanied by the safety alert symbol "⚠ DANGER", "⚠ WARNING", "⚠ CAUTION".

Keep this manual for future reference and to educate new users of this product. This manual should be read in conjunction with the labeling on the product.

Safety precautions are essential when any mechanical or propane fueled equipment is involved. These precautions are necessary when using, storing, and servicing. Using this equipment with the respect and caution demanded will reduce the possibilities of personal injury or property damage.

The following symbols shown below are used extensively throughout these instructions. Always heed these precautions, as they are essential when using any mechanical or propane fueled equipment.

## **DANGER**

Danger indicates an imminently hazardous situation which, if not avoided, will result in death or serious injury.

## **WARNING**

WARNING indicates a potentially hazardous situation which, if not avoided, could result in death or serious injury.

## **CAUTION**

CAUTION indicates a potentially hazardous situation which, if not avoided, may result in minor or moderate personal injury, or property damage.

## **DANGER**

Failure to comply with the precautions and instructions provided with these stoves can result in death, serious bodily injury and property loss or damage from hazards of fire, explosion, burn, asphyxiation, and/or carbon monoxide poisoning.

Only persons who can understand and follow the instructions should use or service these stoves.

If you need assistance or information such as an instruction manual or labels, contact The Coleman Company, Inc.

### **CALIFORNIA PROPOSITION 65:**

**WARNING:** This fuel, and by products of combustion of this fuel, contain chemicals known to the state of California to cause cancer, birth defects, or other reproductive harm.

## **WARNING**

- This product is fueled by propane gas. Propane gas is invisible, odorless, and flammable. An odorant is normally added to help detect leaks and can be described as a "rotten egg" smell. The odorant can fade over time so leaking gas is not always detectable by smell alone.
- Propane gas is heavier than air and leaking propane will sink to the lowest level possible. It can ignite by ignition sources including matches, lighters, sparks or open flames of any kind many feet away from the original leak. Use only propane gas set up for vapor withdrawal.
- Propane gas should be stored or used in compliance with local ordinances and codes or with ANSI/NFPA 58. Turn off propane when not in use.

## **WARNING**

Not for home or recreational vehicle use.

We cannot foresee every use which may be made of our products.

**Check with your local fire safety authority if you have questions about use.**

Other standards govern the use of fuel gases and heat producing products for specific uses. Your local authorities can advise you about these.

- Never refill disposable cylinders.
- Use the preset regulator that came with the stove. Do not attempt to adjust.
- Use only Coleman® accessories or parts. During stove set-up, check all fittings for leaks using soapy water. Never use a flame.

## DANGER



### CARBON MONOXIDE HAZARD

- This stove is a combustion appliance. All combustion appliances produce carbon monoxide (CO) during the combustion process. This product is designed to produce extremely minute, non-hazardous amounts of CO if used and maintained in accordance with all warnings and instructions. Do not block air flow into or out of the stove.
- Carbon Monoxide (CO) poisoning produces flu-like symptoms, watery eyes, headaches, dizziness, fatigue and possibly death. You can't see it and you can't smell it. It's an invisible killer. If these symptoms are present during operation of this product **get fresh air immediately!**
- **For outdoor use only.**
- **Never use inside house, camper, tent, vehicle or other unventilated or enclosed areas. This stove consumes air (oxygen). Do not use in unventilated or enclosed areas to avoid endangering your life.**

## WARNING



### BURN HAZARD

- Never leave stove unattended when hot or in use.
- Keep out of reach of children.

## DANGER



### EXPLOSION - FIRE HAZARD

- Never store propane near high heat, open flames, pilot lights, direct sunlight, other ignition sources or where temperatures exceed 120 °F (49 °C).
- Propane is heavier than air and can accumulate in low places. If you smell gas, leave the area immediately.
- Never install or remove propane tank while outdoor stove is lighted, near flame, pilot lights, other ignition sources or while outdoor stove is hot to touch.
- During lighting and operation, this product can be a source of ignition. Never use the stove in spaces that contain or may contain volatile or airborne combustibles, or products such as gasoline, solvents, paint thinner, dust particles or unknown chemicals. Minimum clearances from combustible materials: 12 inches from the sides and 48 inches from the top.
- Provide adequate clearances around air openings into the combustion chamber.

## CAUTION

### SERVICE SAFETY

- Keep all connections and fittings clean. Inspect propane cylinder and stove propane connections for damage before attaching.
- During set up, check all connections and fittings for leaks using soapy water. Never use a flame. Bubbles indicate a leak. Check that the connection is not cross-threaded and that it is tight. Perform another leak check. If there is still a leak, remove the cylinder and contact Coleman for service or repairs.
- Use as a cooking appliance only. Never alter in any way or use with any device or part not expressly approved by Coleman.
- Clean stove frequently to avoid grease accumulation and possible grease fires.

## Technical Characteristics

Input: 12.5 MJ/h per burner  
Category: Pressure regulated propane  
Fuel: 16.4 oz. disposable propane cylinders  
Regulator: 5430  
Injector: 0.42 mm

## To Set Up

### DANGER



#### CARBON MONOXIDE HAZARD

- For outdoor use only.
- Never use inside house, camper, tent, vehicle or other unventilated or enclosed areas. This stove consumes air (oxygen). Do not use in unventilated or enclosed areas to avoid endangering your life.

**NOTE:** Use Coleman® 16.4 oz. disposable propane cylinders. The LP-gas cylinder(s) used with stoves must be constructed and marked in accordance with the specifications for LP-gas cylinders of the U.S. Department of Transportation or Transport Canada, CAN/CSA B339.

1. Remove components from carton. (Fig. 1)

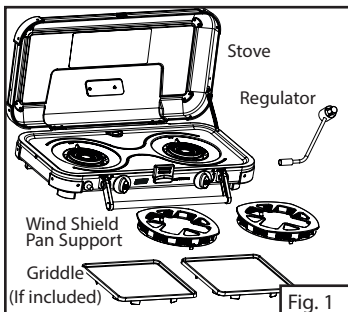

2. To open the lid, move the handle slightly to the "✓" location. Pull the latch hook panel out and push it upwards right above the handle to release. (Fig. 2)  
**NOTE:** The handle can't be pulled down fully.

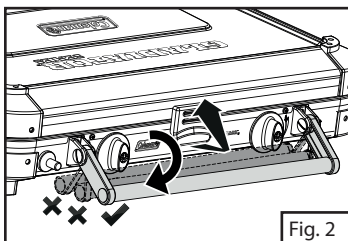

3. Assemble Lid Stopper to stove. (Fig. 3)

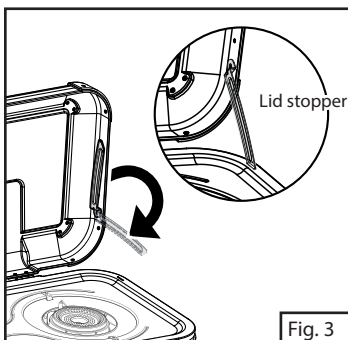

4. Install Wind Shield Pan Support as shown (Fig. 4). Please place cooking pot / pan directly on the the Pan Supports.

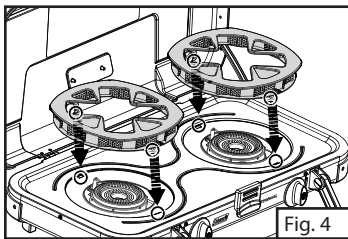

5. Optionally, you may install the griddles (if included) as shown. (Fig. 5)

**NOTE:** Don't use griddle without Wind Shield Pan Support.

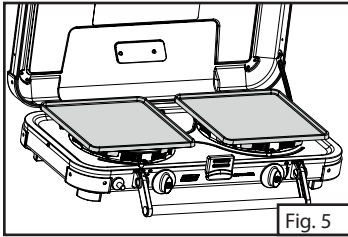

**NOTE TO PREVENT DAMAGE WHICH WILL VOID THE WARRANTY:**

- Do not use pots, pans, ovens, etc., on this griddle surface.
- Do not use this griddle on a campfire or other open fire.
- Use this griddle only on the Coleman® stove for which it was designed.

6. Control Knob Identification (Fig. 6)

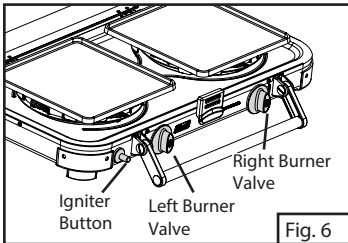

7. Close both burner valves firmly. (Fig. 7)

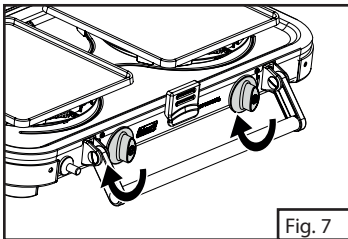

**CAUTION**

**SERVICE SAFETY**

- Keep all connections and fittings clean. Inspect propane cylinder and stove propane connections for damage before attaching.
- During set up, check all connections and fittings for leaks using soapy water. Bubbles indicate a leak. Never use a flame.

8. Screw regulator into stove hand tight. (Fig. 8)
9. Remove plastic cap from top of propane bottle and screw propane bottle into regulator hand tight. (Fig. 9)

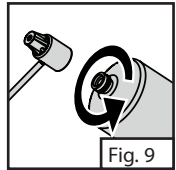
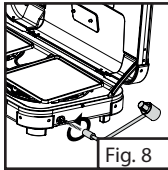

10. Propane cylinder correctly installed. (Fig. 10)
11. Never operate stove with propane cylinder in an inverted position. (Fig. 11)

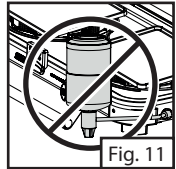
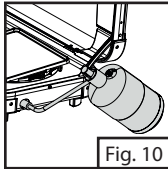

Check that all seals between the appliance and the gas cylinder are in place and in good condition before connecting the gas cartridge. Remove all transit protection material.

DO NOT move the appliance during operation. After use, turn the gas cylinder valve off, wait for the flame to go out, then turn the appliance control valve(s) off.

Flexible gas hose maximum length is 1.5 meters, Avoid twisting or kinking the flexible hose.

## Leak Check

### ⚠ WARNING

- Perform leak test outdoors.
- Extinguish all open flames.
- NEVER leak test when smoking.
- Do not use the outdoor stove until connection has been leak tested and does not leak.

### ⚠ WARNING



#### BURN HAZARD

- Never leave stove unattended when hot or in use.
- Keep out of reach of children.

## To Light

### ⚠ DANGER



#### EXPLOSION - FIRE HAZARD

- Propane is heavier than air and can accumulate in low places. If you smell gas, leave the area immediately.
- Always attach or detach propane source outdoors; never while stove is lighted, near flame, pilot lights, other ignition sources or while stove is hot to touch.
- This stove is red hot during use and can ignite flammables too close to the burners. Keep flammables at least 12 inches from the sides and 48 inches from the top of the stove. Keep gasoline and other flammable liquids and vapors well away from stove.
- The stove must not be exposed to flammable vapors or liquids during lighting.

## INSTASTART™

### Electronic Ignition Stoves

1. Set stove on sturdy, flat surface.  
**For outdoor use only.**
2. Open burner valve and repeatedly push igniter button until burner ignites. (Fig. 12)
3. Repeat for both burners.  
**NOTE:** If the igniter still fails to light stove, use match to light burner. If the stove is wet the igniter may not spark.

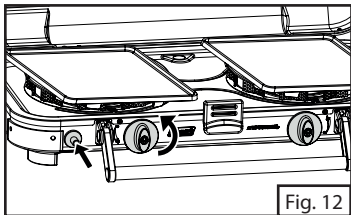

### Match Lighting

1. Set stove on sturdy, flat surface.  
**For outdoor use only.**
2. Hold lighted match near burner and open burner valve. (Fig. 13)
3. Repeat for both burners.

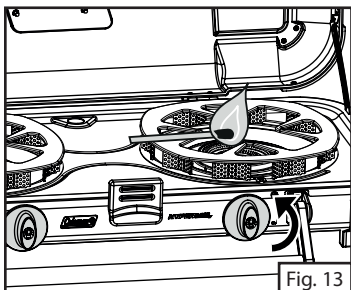

4. Adjust flame with burner valves. (Fig. 14). Flame should be blue with a hint of yellow on tips.

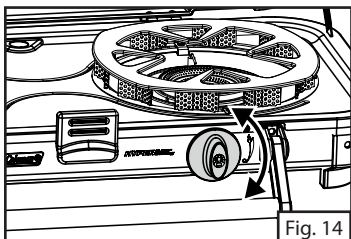

## To Turn Off

1. Close the burner valves firmly. (Fig. 15)

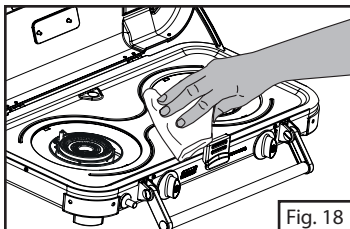
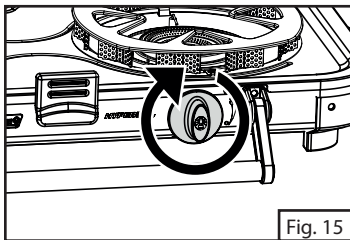

## To Clean

1. Make sure stove is cool.
2. Move stove away from flame (including pilot lights) and other ignition sources.
3. Remove propane cylinder from regulator and replace protective cap on cylinder. (Fig. 16)
4. Remove regulator from stove. (Fig. 17)

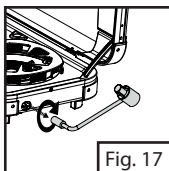
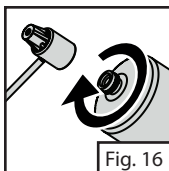

To check if the gas cylinder is empty, disconnect the cylinder from the appliance and shake from side to side.

If there is no sound or movement of liquid, the cylinder is empty.

Annual service by an authorised person is recommended. Or if any of the following conditions are noticed; incomplete ignition, appreciable yellow tipping, carbon deposition, lifting, floating, lighting back or objectionable odor.

DO NOT use this appliance if it has damaged or worn seals. DO NOT use this appliance if it is leaking, damaged or does not operate properly.

## Cleaning the Griddle (if included)

1. Make sure stove and griddle are cool.
2. Wipe clean with soft cloth and mild dish detergent. Do not use abrasives on the non-stick griddle surface.

### MAINTENANCE

- Keep stove area clear and free from combustible materials, gasoline and other flammable vapors and liquids.
- Do not obstruct the flow of combustion and ventilation air.
- A good flame should be blue with minimal yellow tip. Some yellow tips on flames are acceptable as long as no carbon or soot deposits appear.
- Wipe clean with soft cloth and mild dish detergent. Do not use abrasives. (Fig. 18)



## To Store

### ⚠ DANGER



#### EXPLOSION - FIRE HAZARD

- Never store propane near high heat, open flames, pilot lights, direct sunlight, other ignition sources or where temperatures exceed 120 degrees F (49 °C).
- The cylinder must be disconnected when the stove is in storage.

1. For storage or transport, the regulator may be located between the Wind Shield Pan Support. (Fig. 19)
2. Place the griddle (if included) on the Wind Shield Pan Support.

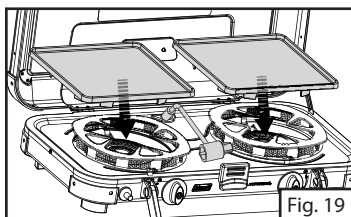

3. Secure the lid latch.
4. To carry the stove, firmly grasp the stove by the handle. (Fig. 20)

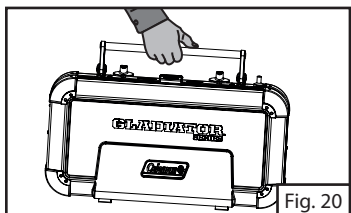

## Things You Should Know

- It is unsafe and illegal in some places to store or use propane cylinders of greater than 1.14 kg (2.5 lbs.) water capacity (approximately 1 lb. propane) in occupied enclosures.
- The usual storage areas for camping and picnic equipment are the basement, attic, or garage. To avoid the accumulation of dust, cobwebs, etc., that is common in these storage areas, place your stove in a plastic bag and seal it with a rubber band.
- For repair service call one of the numbers listed on the front cover for location of your nearest Coleman Service Center.
- If not completely satisfied with the performance of this product, please call one of the numbers listed on the cover of this manual.

[www.coleman.com](http://www.coleman.com)

# Replacement Parts List

Item	Part No.	Description
1	5010002508	Windshield Pan Support - Hyperflame
2	R430B565T	Regulator Assembly
3	5010002509	Handle Assy - 9966 Models
4	5010002507	Knob - 9966 Models

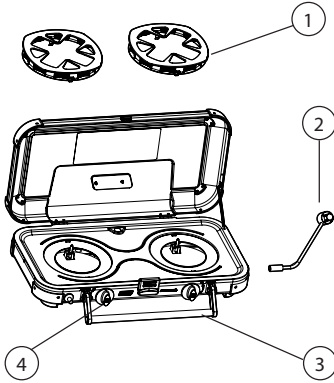

## Accessories:

5	2000017528	Griddle
---	------------	---------



## Limited Three Year Warranty

### EXPRESS WARRANTY

Coleman Brands Pty. Ltd. ("Coleman") warrants that for a period of three (3) years from the date of original retail purchase, this product will be free from defects in material and workmanship. Coleman will, depending on the circumstances, refund, repair or replace this product or any component of the product found to be defective during the warranty period. Replacement will be made with a new or remanufactured product or component. If the product is no longer available, replacement may be made with a similar product of equal or greater value. To the extent permitted by law and subject to your non-excludable rights under the Australian Consumer Law (Schedule 2 to the Competition and Consumer Act 2010 (Cth)) and the New Zealand Consumer Guarantees Act, which are not limited to a one (1) year period, this is your exclusive remedy for any breach of this limited warranty or for any other claims otherwise relating to this limited warranty.

In Australia, our goods come with guarantees that cannot be excluded under the Australian Consumer Law. You are entitled to a replacement or refund for a major failure and compensation for any other reasonably foreseeable loss or damage. You are also entitled to have the goods repaired or replaced if the goods fail to be of acceptable quality and the failure does not amount to a major failure. The benefits provided under this warranty are in addition to and do not affect purchaser's statutory rights under the Australian Consumer Law or other rights at law.

This warranty is valid for the original retail purchaser from the date of initial retail purchase and is not transferable. Please keep your proof of purchase documentation, such as the original sales receipt or the relevant credit card statement. Proof of purchase is required to obtain warranty performance. Coleman dealers, Coleman service centres, or retail stores selling Coleman® products do not have the right to alter, modify or in any way change the terms and conditions of this warranty. The warranty is valid only for products that are purchased new and unused in Australia and New Zealand, from Coleman or Coleman dealers or retailers.

### WARRANTY EXCLUSIONS AND LIMITATIONS

THE AUSTRALIAN CONSUMER LAW PROVIDES CONSUMERS WITH CERTAIN 'CONSUMER GUARANTEES'. THESE GUARANTEES APPLY WHERE THE GOODS AND SERVICES COLEMAN SUPPLIES TO YOU ARE OF A KIND ORDINARILY ACQUIRED FOR PERSONAL, DOMESTIC OR HOUSEHOLD USE OR COST LESS THAN \$40,000, AND IN THE CASE OF GOODS, ARE NOT RE-SUPPLIED BY YOU. NOTHING IN THIS LIMITED WARRANTY EXCLUDES, RESTRICTS OR MODIFIES RIGHTS WHICH YOU HAVE UNDER THE AUSTRALIAN CONSUMER LAW IN RESPECT OF THE CONSUMER GUARANTEES AND ALL OF THE PROVISIONS IN THIS SECTION ARE TO BE READ SUBJECT TO THE AUSTRALIAN CONSUMER LAW.

This warranty does not cover: (a) normal wear of the product and/or its parts; (b) parts that are not genuine Coleman® parts, consumables, lost parts and accessories; (c) damage resulting from any of the following: negligent use or misuse of the product, commercial use of the product, use contrary to the operating instructions; disassembly, repair or alteration by anyone other than Coleman or Coleman service centre, the use of a part other than a genuine Coleman® part; or (d) acts of God, such as fire, flood, hurricanes and tornadoes.

To the extent permitted by the Australian Consumer Law, *the Competition and Consumer Regulation 2010* and the *New Zealand Consumer Guarantees Act*, Coleman's liability is limited, depending on the circumstances, to refund, replacement or repair of Coleman® products or components.

For the avoidance of doubt, any and all other warranties or conditions which are not guaranteed by the Australian Consumer Law, the Competition and Consumer Regulation 2010 and the New Zealand Consumer Guarantees Act and which are not expressly included in this warranty as additional warranties or conditions are expressly excluded, including liability for incidental or consequential damages caused by the breach of any express or implied warranty or condition.

### MAKING A WARRANTY CLAIM - RETURN TO COLEMAN FOR REPAIR

Take the product to an authorised Coleman retailer or Coleman service centre as soon as the warranty claim arises. You may locate the nearest authorised Coleman retailer or Coleman service centre by visiting [www.coleman.com](http://www.coleman.com) or calling 1800 224 350 or + 61 2 8762 5000. Please ensure that you provide a written description of the problem with the product, together with your contact name, address and telephone number and proof of purchase.

Subject to the applicable consumer laws in your jurisdiction, you must pay for the costs of transporting the product, including packaging, freight and insurance costs, to an authorised Coleman retailer or Coleman service centre for warranty service. If the warranty claim is substantiated and accepted by Coleman, Coleman will at its cost, repair or replace any product or parts and return the product to you. Additionally, if the warranty claim is substantiated and accepted by Coleman, Coleman will reimburse you for the costs of transporting the product to an authorized Coleman retailer or Coleman service centre. Coleman reserves the right to seek reimbursement for any costs and expenses incurred for a warranty claim if the product is found to be in good working order.

If you have any questions regarding this warranty please call 1800 224 350 or + 61 2 8762 5000.

### Coleman Brands Pty. Ltd.

ABN 74 091 681 195  
Suite W2C1, 75-85 O'Riordan Street,  
Sydney Corporate Park, Alexandria, NSW 2015  
Australia  
Telephone: 1800 224 350 or + 61 2 8762 5000  
Email: [customerservice@colemanaust.com.au](mailto:customerservice@colemanaust.com.au)

[www.coleman.com](http://www.coleman.com)



**Coleman Brands Pty. Ltd.**

ABN 74 091 681 195, Suite W2C1, 75-85 O'Riordan Street, Sydney Corporate Park, Alexandria,  
NSW 2015, Australia

Telephone: 1800 224 350 or + 61 2 8762 5000

**[www.coleman.com](http://www.coleman.com)**

© 2014 The Coleman Company, Inc. All rights reserved. Coleman®,  and  are registered trademarks of The Coleman Company, Inc.

The Coleman Company, Inc., a Jarden Corporation company (NYSE:JAH)

4010041866 (ECN20044032-01)